

PFT510

BATTERY-POWERED VIC-PRESS™ TOOL FOR VIC-PRESS SCHEDULE 10S SYSTEM PRODUCTS



Vic-Press™ SCHEDULE 10S SYSTEM PRODUCTS



WARNING



Failure to follow instructions and warnings could result in serious personal injury, property damage, and/or product damage.

- Before operating or servicing the PFT510 Vic-Press Schedule 10S Tool read all instructions in this manual and all warning labels on the tool.
- Before attempting to install any Vic-Press products, read the I-P500 Field Installation Handbook.
- Wear safety glasses, hardhat, foot protection, and hearing protection.
- Save this operating and maintenance manual.

If you need additional copies of any literature, or if you have questions concerning the safe and proper operation of this tool, contact Victaulic, P.O. Box 31, Easton, PA 18044-0031, Phone: 1-800-PICK VIC, E-Mail: pickvic@victaulic.com

INDEX

Hazard Identification1
 Operator Safety Instructions.2
 Introduction3
 Receiving The Tool4
 Contents of Tool Case4
 Contents of Accessory Case.4
 Using the Dolly to Transport the Tool or
 Accessory Case.5
 Battery and Battery Charger Information6
 Specifications6
 Temperature Requirements for Charging
 Batteries7
 Temperature Requirements for Operating
 the PFT510 Tool7
 Approximate Amount of Presses with a
 Fully-Charged Battery7
 Tool Nomenclature.8
 Tool Setup9
 Pressing Operation for ½-inch/21.3-mm,
 ¾-inch/26.9-mm, and 1-inch/33.7-mm
 Sizes12
 Pressing Operation for 1 ½-inch/48.3-mm
 and 2-inch/60.3-mm Sizes14
 Standard Vic-Press Jaw or
 Vic-Press Adapter Jaw Removal.18
 Maintenance18
 Battery and Battery Charger
 Maintenance20
 Troubleshooting21
 Indicator Lights/Sounds.22
 EC Declaration of Conformity23

HAZARD IDENTIFICATION

Definitions for identifying the various hazard levels are provided below.



When you see this symbol, be alert to the possibility of personal injury. Carefully read and fully understand the message that follows.

! DANGER

- The use of the word “DANGER” identifies an immediate hazard with a likelihood of death or serious personal injury if instructions, including recommended precautions, are not followed.

! WARNING

- The use of the word “WARNING” identifies the presence of hazards or unsafe practices that could result in death or serious personal injury if instructions, including recommended precautions, are not followed.

! CAUTION

- The use of the word “CAUTION” identifies possible hazards or unsafe practices that could result in personal injury and product or property damage if instructions, including recommended precautions, are not followed.

NOTICE

- The use of the word “NOTICE” identifies special instructions that are important but not related to hazards.

OPERATOR SAFETY INSTRUCTIONS

Use of this tool requires dexterity and mechanical skills, as well as sound safety habits. Although this tool is manufactured for safe, dependable operation, it is impossible to anticipate all combinations of circumstances that could result in an accident. The following instructions are recommended for safe operation of this tool. The operator is cautioned to always practice "safety first" during each phase of use, including setup and maintenance. It is the responsibility of the owner, lessee, or user of this tool to ensure that all operators read this manual and fully understand the operation of this tool.

Read this manual before operating or maintaining this tool. Become familiar with the tool's operations, applications, and limitations. Be particularly aware of its specific hazards. Store this manual in a clean area where it is always readily available. Additional copies of this manual are available upon request.

- 1. Avoid using the tool in dangerous environments.** Do not expose the tool to rain, and do not use the tool in damp or wet locations. Do not use the tool near flammable liquids and gaseous, explosive environments. Keep the work area well lit. Allow sufficient space to operate the tool properly.
- 2. Inspect the equipment.** Before using the tool, check all moveable parts for any obstructions. Check for alignment of moving parts, breakage, mounting problems, and other conditions that may affect tool or Vic-Press jaw operation. Do not attempt to repair damaged Vic-Press jaws.
- 3. Prevent accidental startups.** Do not carry the tool with your finger on the trigger.
- 4. Wear proper apparel.** Do not wear loose clothing, jewelry, or anything that can become entangled in moving parts. Non-skid footwear and rubber gloves are recommended when working outdoors.
- 5. Wear protective items when working with tools.** Always wear safety glasses, hardhat, foot protection, and hearing protection.
- 6. Stay alert.** Do not operate the tool if you are drowsy from medication or fatigue. Avoid horseplay around the equipment.
- 7. Keep visitors away from the immediate work area.** All visitors should be kept a safe distance from the equipment at all times.
- 8. Keep work areas clean.** Keep the work area around the tool clear of any obstructions that could limit the movement of the operator. Clean up any oil/spills.
- 9. Secure the work.** Use clamps, vices, or pipe hangers to secure the work.
- 10. Keep hands and tools away from the Vic-Press jaws during the pressing operation.** Avoid all pinch points.
- 11. Do not over-reach.** Maintain proper footing and balance at all times.
- 12. Do not force the tool.** Do not force the tool or accessories to perform any functions beyond their capabilities. Do not overload the tool.
- 13. Always remove the battery before lubricating tool components.** Only authorized personnel should lubricate tool components.
- 14. Maintain tools with care.** Keep tools clean at all times to ensure proper and safe performance. Follow all maintenance instructions. Do not lubricate tools with flammable or volatile liquids, such as kerosene, diesel fuel, etc.
- 15. Always operate, inspect, and maintain the tool in accordance with all regulations that apply to hand-held, battery-powered tools.**
- 16. Use only Victaulic or authorized accessories.** Use of any other parts may result in a voided warranty, improper operation, and hazardous situations.
- 17. Do not remove any labels from the tool.** Replace any damaged or worn labels.

18. **DO NOT ALTER THE PFT510 VIC-PRESS SCHEDULE 10S TOOL OR JAWS IN ANY WAY.** Alterations to any tool components may result in improper product installation and will void the Victaulic warranty.
19. Store tools in a dry, secure area when not in use.
20. Use only rechargeable batteries and battery chargers supplied or authorized by Victaulic.
21. **Keep the battery away from metal objects that can make a connection from one terminal to another.** Shorting the battery terminals may cause burns or a fire.
22. **Avoid contact with batteries that may be leaking.** Burns or skin irritation can occur from contact with leaking batteries.
23. **Do not use the tool, batteries, and the battery charger at ambient temperatures outside the ranges listed in this manual.**
24. **Do not dispose of batteries with normal domestic waste.** Batteries must be disposed of properly, in accordance with local environmental requirements.

INTRODUCTION

NOTICE

- Drawings and/or pictures in this manual may be exaggerated for clarity.
- The tool, along with this operating and maintenance instructions manual, contains trademarks, copyrights, and/or patented features that are the exclusive property of Victaulic.

The Victaulic PFT510 Vic-Press Schedule 10S Tool is designed for joining only Victaulic Vic-Press Schedule 10S System products with ASTM A-312 Schedules 5S and 10S stainless steel pipe (Types 304/304L or 316/316L) in ½-inch/ 21.3-mm, ¾-inch/26.9-mm, 1-inch/33.7-mm, 1½-inch/48.3-mm, and 2-inch/60.3-mm sizes.

The PFT510 must be equipped with the proper size standard Vic-Press jaw or Vic-Press adapter jaw/Vic-Press ring that corresponds with the size of pipe and Vic-Press System Products being installed.

The PFT510 is a Victaulic tool manufactured by Klauke* for industrial and trade use only. Refer to the back cover of this manual for the EC Declaration of Conformity.

CAUTION

- **The PFT510 must be used only with Victaulic Vic-Press Schedule 10S System Products and stainless steel pipe, as outlined in the “Introduction” section.**

Failure to follow this instruction could cause improper product assembly, resulting in joint leakage, tool damage, and property damage.

* Klauke is a registered trademark of the Textron Company

RECEIVING THE TOOL

The PFT510 tool, Vic-Press jaws, battery charger, and batteries are shipped in sturdy storage containers. Upon receipt of the tool, make sure all necessary parts are included. If any parts are missing, contact Victaulic.

CONTENTS OF TOOL CASE



CONTENTS OF ACCESSORY CASE



TOOL CASE

Qty.	Description
1	PFT510 Vic-Press Schedule 10S Tool
1 Each	Standard Vic-Press Jaws for ½-inch/21.3-mm, ¾-inch/26.9-mm, and 1-inch/33.7-mm Vic-Press Schedule 10S System Products*
2	18-volt Rechargeable Battery
1	Battery Charger with Instruction Sheet
2	PFT510 Operating and Maintenance Instructions Manual (TM-PFT510)
1	Paint Stick
1	Wire Brush
1	Pipe Marking Gauges for ½-inch/21.3-mm, ¾-inch/26.9-mm, and 1-inch/33.7-mm Pipe

* These Vic-Press Jaws may be shipped in the Accessory Case, depending on the part code that is ordered.

ACCESSORY CASE

Qty.	Description
1 Each	Vic-Press Ring for 1½-inch/48.3-mm and 2-inch/60.3-mm Vic-Press Schedule 10S System Products
1	Vic-Press Adapter Jaw
1	Victaulic Vic-Press Schedule 10S System Products Field Installation Handbook (I-P500)
1	Pipe Marking Gauge Instructions (I-P500.Gauge)
1	Pipe Marking Gauges for 1½-inch/48.3-mm and 2-inch/60.3-mm Pipe
1	Paint Stick
1	Wire Brush

www.victaulic.com

VICTAULIC IS A REGISTERED TRADEMARK OF VICTAULIC COMPANY.

TM-PFT510_4

REV_D

USING THE DOLLY TO TRANSPORT THE TOOL OR ACCESSORY CASE

Due to the weight of the tool and accessory cases, a dolly is provided for ease of transportation.

To install the dolly onto the back of the tool or accessory case:



1. Engage the upper bracket of the dolly with the upper bar on the back of the tool or accessory case, as shown above.



2. Push in the button located at the lower bracket of the dolly (between the wheels). Engage this lower bracket with the lower bar on the back of the tool or accessory case. Release the button and make sure the dolly is secured to the case.

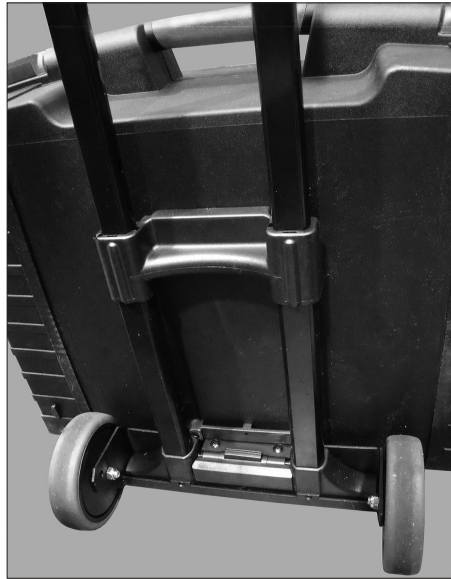

3. Raise the handle to allow for ease of rolling the case.

NOTICE

- To prevent the tool or accessory case from teetering on the dolly and becoming damaged, remove the dolly before opening the case. The case should lie flat on the ground to prevent damage to any of the components.
- Remove the dolly by pushing in the button located at the lower bracket of the dolly. Disengage the lower bracket from the lower bar, and lift the dolly up and away from the back of the case.

BATTERY AND BATTERY CHARGER INFORMATION

⚠
DANGER



- Make sure the voltage on the battery charger's label matches the voltage of the electrical source.

Failure to follow this instruction could result in death or serious personal injury.

SPECIFICATIONS

Battery Charger Input (AC 120 volts, 50-60 Hz)
Contact Victaulic for alternate voltages

Battery Charger Output (DC 7.2 volts – 18 volts)
18-volt Battery Weight (1.4 pounds/0.65 kg)

The battery must be charged completely before attempting to press any Vic-Press System Products. Only the battery charger, supplied with the tool, should be used. Refer to the “Temperature Requirements for Charging Batteries” section.



1. Plug the battery charger into a proper AC power source.

1a. Insert the battery into the battery charger, as shown above.

1b. When a battery is inserted into the battery charger, the red indicator light will illuminate. After approximately 25 minutes, the indicator light will change from red to green, which is a notification that the battery is charged completely. Always refer to the instruction sheet supplied with the battery charger for complete information.



2. Press the button on the battery to remove it from the battery charger, as shown above.

3. After charging a battery, always unplug the battery charger from the AC power source.

If the battery is not charged sufficiently at the beginning of a pressing operation, the piston will advance briefly and then retract. The battery must be charged or replaced with a fully-charged battery before attempting to perform the next press.

If the battery runs low during the pressing operation, the tool will stop before completing the press. **NOTE: THIS PRESSED JOINT IS NOT ACCEPTABLE.** The fitting must be pressed again with a tool that has a fully-charged battery. After replacing the tool's battery, the pressing operation can be completed.

TEMPERATURE REQUIREMENTS FOR CHARGING BATTERIES

Do not charge batteries at ambient temperatures less than 50° F/10° C or greater than 104° F/ 40° C.

TEMPERATURE REQUIREMENTS FOR OPERATING THE PFT510 TOOL

Do not operate the PFT510 at ambient temperatures less than 14° F/-10° C or greater than 122° F/50° C.

APPROXIMATE AMOUNT OF PRESSES WITH A FULLY-CHARGED BATTERY

The following table lists the approximate amount of presses, according to pipe size, that can be expected from a fully-charged battery. **NOTE:** The amount of presses may vary with pipe properties, age of the batteries, etc.

Nominal Diameter inches	Actual Pipe Outside Diameter inches/mm	Approximate Amount of Presses from a Fully-Charged Battery
½	0.840 21.3	136
¾	1.050 26.9	110
1	1.315 33.7	87
1½	1.900 48.3	47
2	2.375 60.3	35

TOOL NOMENCLATURE

NOTICE

- Drawings and/or pictures in this manual may be exaggerated for clarity.
- The tool, along with this operating and maintenance instructions manual, contains trademarks, copyrights, and/or patented features that are the exclusive property of Victaulic.

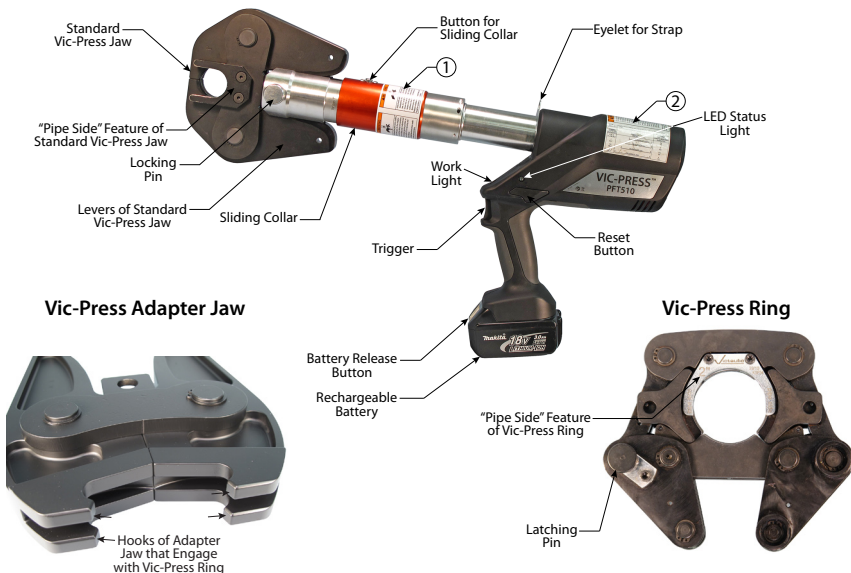

①	<p>WARNING</p> <p>• Keep hands away from pinch points (rollers, standard Vic-Press jaws, Vic-Press Adapter Jaw, etc.) at all times during tool operation. • Ensure the red sliding collar is adjusted and locked to the proper operating position, as outlined in the TM-PFT510 Operating and Maintenance Manual. Failure to follow these instructions could result in serious personal injury.</p>	<p>WARNING</p> <p>• Keep hands away from pinch points (rollers, standard Vic-Press jaws, Vic-Press Adapter Jaw, etc.) at all times during tool operation. • Ensure the red sliding collar is adjusted and locked to the proper operating position, as outlined in the TM-PFT510 Operating and Maintenance Manual. Failure to follow these instructions could result in serious personal injury.</p>	<p>WARNING</p> <p>• Keep hands away from pinch points (rollers, standard Vic-Press jaws, Vic-Press Adapter Jaw, etc.) at all times during tool operation. • Ensure the red sliding collar is adjusted and locked to the proper operating position, as outlined in the TM-PFT510 Operating and Maintenance Manual. Failure to follow these instructions could result in serious personal injury.</p>	<p>WARNING</p> <p>• Keep hands away from pinch points (rollers, standard Vic-Press jaws, Vic-Press Adapter Jaw, etc.) at all times during tool operation. • Ensure the red sliding collar is adjusted and locked to the proper operating position, as outlined in the TM-PFT510 Operating and Maintenance Manual. Failure to follow these instructions could result in serious personal injury.</p>
---	--	--	--	--

②	<p>WARNING</p> <p>• Read and understand the P500 Field Installation Handbook and the TM-PFT510 operating and maintenance manual before attempting to install Vic-Press Schedule 105 System Products. • The PFT510 Vic-Press Schedule 105 Tool is designed for use ONLY with Vic-Press Schedule 105 System Products. DO NOT attempt to install Schedule 5 Pressfit Products with this tool. • Pipe for use with Vic-Press Schedule 105 System Products must meet the minimum pipe-ripple length requirements specified on this label. • Always measure pipe insertion depth by using the Vic-Press Marking Gauge or a ruler or tape measure. Mark the pipe at the correct measurement, specified on this label, by using a marker or paint stick. • Always insert the pipe fully into the fitting. Always position the fitting properly in the standard Vic-Press jaw or Vic-Press ring before attempting to perform the pressing operation. Failure to follow these instructions could cause system failures, resulting in serious personal injury and property damage.</p>	<p>MINIMUM PIPE LENGTHS (mm)</p> <table border="1"> <tr> <th>PIPE SIZE (mm)</th> <th>MINIMUM PIPE LENGTH (mm)</th> </tr> <tr> <td>100</td> <td>113</td> </tr> <tr> <td>125</td> <td>141</td> </tr> <tr> <td>150</td> <td>169</td> </tr> <tr> <td>175</td> <td>197</td> </tr> <tr> <td>200</td> <td>225</td> </tr> <tr> <td>225</td> <td>253</td> </tr> <tr> <td>250</td> <td>281</td> </tr> <tr> <td>275</td> <td>309</td> </tr> <tr> <td>300</td> <td>337</td> </tr> <tr> <td>325</td> <td>365</td> </tr> <tr> <td>350</td> <td>393</td> </tr> <tr> <td>375</td> <td>421</td> </tr> <tr> <td>400</td> <td>449</td> </tr> <tr> <td>425</td> <td>477</td> </tr> <tr> <td>450</td> <td>505</td> </tr> <tr> <td>475</td> <td>533</td> </tr> <tr> <td>500</td> <td>561</td> </tr> <tr> <td>525</td> <td>589</td> </tr> <tr> <td>550</td> <td>617</td> </tr> <tr> <td>575</td> <td>645</td> </tr> <tr> <td>600</td> <td>673</td> </tr> <tr> <td>625</td> <td>701</td> </tr> <tr> <td>650</td> <td>729</td> </tr> <tr> <td>675</td> <td>757</td> </tr> <tr> <td>700</td> <td>785</td> </tr> <tr> <td>725</td> <td>813</td> </tr> <tr> <td>750</td> <td>841</td> </tr> <tr> <td>775</td> <td>869</td> </tr> <tr> <td>800</td> <td>897</td> </tr> <tr> <td>825</td> <td>925</td> </tr> <tr> <td>850</td> <td>953</td> </tr> <tr> <td>875</td> <td>981</td> </tr> <tr> <td>900</td> <td>1009</td> </tr> </table>	PIPE SIZE (mm)	MINIMUM PIPE LENGTH (mm)	100	113	125	141	150	169	175	197	200	225	225	253	250	281	275	309	300	337	325	365	350	393	375	421	400	449	425	477	450	505	475	533	500	561	525	589	550	617	575	645	600	673	625	701	650	729	675	757	700	785	725	813	750	841	775	869	800	897	825	925	850	953	875	981	900	1009
PIPE SIZE (mm)	MINIMUM PIPE LENGTH (mm)																																																																					
100	113																																																																					
125	141																																																																					
150	169																																																																					
175	197																																																																					
200	225																																																																					
225	253																																																																					
250	281																																																																					
275	309																																																																					
300	337																																																																					
325	365																																																																					
350	393																																																																					
375	421																																																																					
400	449																																																																					
425	477																																																																					
450	505																																																																					
475	533																																																																					
500	561																																																																					
525	589																																																																					
550	617																																																																					
575	645																																																																					
600	673																																																																					
625	701																																																																					
650	729																																																																					
675	757																																																																					
700	785																																																																					
725	813																																																																					
750	841																																																																					
775	869																																																																					
800	897																																																																					
825	925																																																																					
850	953																																																																					
875	981																																																																					
900	1009																																																																					

TOOL SETUP

1. Insert the charged battery into the tool until it locks into position with an audible click.

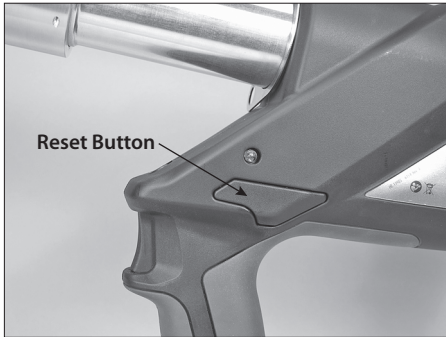

2. Installation of the standard Vic-Press jaw or Vic-Press adapter jaw is possible only when the drive rollers are retracted sufficiently. If necessary, press the reset button until the drive rollers are retracted.

CAUTION

- Use caution when releasing the locking pin. The locking pin is under spring-loaded pressure.

Failure to follow this instruction could result in personal injury.

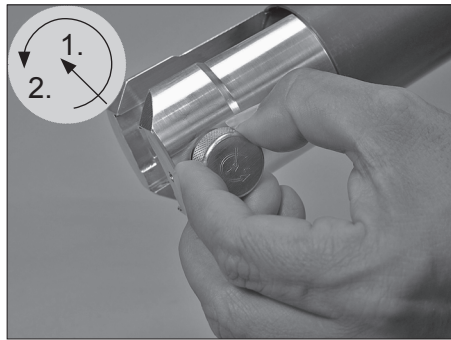

3. Release the locking pin by pushing in and turning counterclockwise. Use caution when releasing the locking pin. The locking pin is under spring-loaded pressure.

4. Select the proper size standard Vic-Press jaw or Vic-Press adapter jaw for the pipe/fitting size being installed. **NOTE:** The size is stamped on the standard Vic-Press jaw/Vic-Press ring.

5. The red sliding collar must be adjusted to the proper operating position for the jaw size to be used. **NOTE:** If necessary, press the trigger to move the rollers forward if the red sliding collar does not engage in the proper operating position.

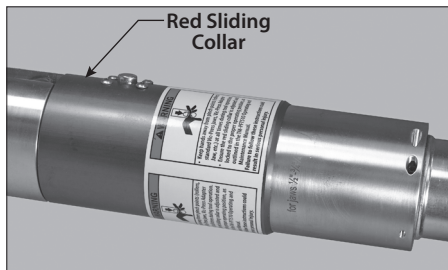

The position shown above (red sliding collar engaged in the upper/forward position) must be used for ½-inch/21.3-mm and ¾-inch/26.9-mm sizes.

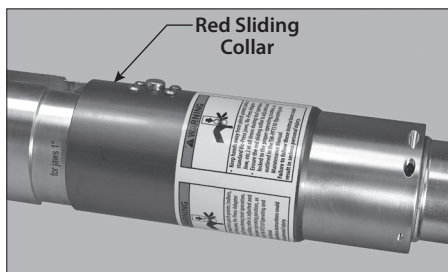

The position shown above (red sliding collar engaged in the middle/center position) must be used for the 1-inch/33.7-mm size.



The position shown above (red sliding collar engaged in the lower/back position) must be used for 1 ½-inch/48.3-mm and 2-inch/60.3-mm sizes.

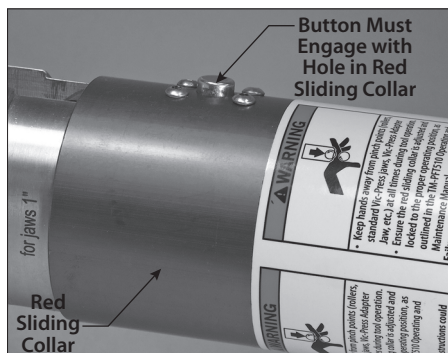

6. After adjusting the red sliding collar to the appropriate position, make sure the button is engaged completely with the hole in the sliding collar, as shown above. **NOTE:** The button will pop up with an audible click, ensuring that the red sliding collar is in the locked position.



7. Install the standard Vic-Press jaw or Vic-Press adapter jaw into the tool. Make sure the standard Vic-Press jaw or Vic-Press adapter jaw aligns properly to permit insertion of the locking pin.

⚠ CAUTION

- Keep fingers away from the locking pin/locking pin spring pinch point.

Failure to follow this instruction could result in personal injury.



7a. Push the locking pin fully into the tool until it clicks.

⚠ CAUTION

- Make sure the locking pin is fully engaged in the tool before attempting to perform the pressing operation.

The tool will not operate correctly if the locking pin is not fully engaged, resulting in tool damage.

PRESSING OPERATION FOR 1/2-INCH/21.3-MM, 3/4-INCH/ 26.9-MM, AND 1-INCH/33.7-MM SIZES

WARNING

- Before operating the PFT510 Vic-Press Schedule 10S Tool, read the I-P500 Field Installation Handbook, and follow all instructions in the previous sections of this manual.
- Wear hardhat, safety glasses, foot protection, and hearing protection.
- The PFT510 Vic-Press Schedule 10S Tool is designed for use ONLY with Vic-Press Schedule 10S System Products. Refer to the “Introduction” section. DO NOT attempt to install Schedule 5 Pressfit Products with this tool.
- The proper size standard Vic-Press jaw must be used for the fitting and pipe size being installed.
- Inspect the tool and standard Vic-Press jaw for loose, broken, or damaged parts before attempting to perform the pressing operation.
- **DO NOT ALTER THE PFT510 VIC-PRESS SCHEDULE 10S TOOL OR JAWS IN ANY WAY. ALTERATIONS TO ANY TOOL COMPONENTS MAY RESULT IN IMPROPER PRODUCT INSTALLATION AND WILL VOID THE VICTAULIC WARRANTY.**
- Keep fingers and hands away from all pinch points during the pressing operation.

Failure to follow these instructions could result in serious personal injury, property damage, and joint failure.

1. Check the standard Vic-Press jaw for damage or wear before performing the pressing operation. Replace any damaged or worn standard Vic-Press jaws.



2. Open the standard Vic-Press jaw by squeezing the levers.

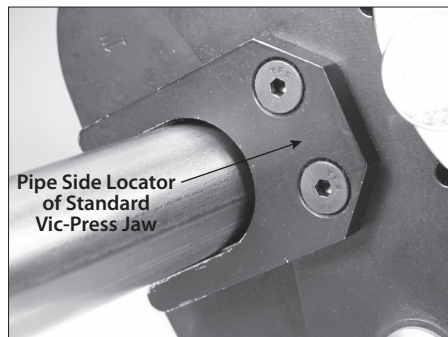

3. Position the standard Vic-Press jaw over the Vic-Press Schedule 10S fitting. Make sure the standard Vic-Press jaw cavity aligns with the seal pocket bead of the fitting. The “pipe side” locator of the standard Vic-Press jaw must be positioned over the pipe, as shown above.
NOTE: Always position the tool/standard Vic-Press jaw onto the fitting at a right angle to the pipe axis. **DO NOT ATTEMPT TO REMOVE THE “PIPE SIDE” LOCATOR FROM THE STANDARD VIC-PRESS JAW. ALTERATIONS TO ANY TOOL COMPONENTS MAY RESULT IN IMPROPER PRODUCT INSTALLATION AND WILL VOID THE VICTAULIC WARRANTY.**

3a. Release the levers to allow the standard Vic-Press jaw to close around the fitting.

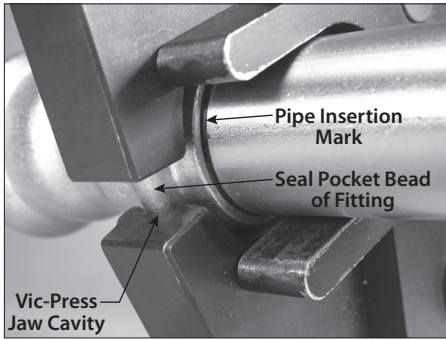

4. While positioning the standard Vic-Press jaw, make sure the pipe remains inserted fully in the fitting and that the Vic-Press jaw cavity aligns/engages with the seal pocket bead of the fitting, as shown above. The end of the fitting must be flush with the pipe insertion mark. Always refer to the I-P500 Field Installation Handbook for pipe preparation and marking requirements.



CAUTION

- **Make sure the seal pocket bead of the fitting is seated fully in the standard Vic-Press jaw cavity before performing the pressing operation.**

Failure to follow this instruction will cause an improper press, resulting in property damage.

5. Place hands, as shown above. Keep hands away from the standard Vic-Press jaw and other pinch points at all times during the pressing operation. **NOTE:** The cylinder of the tool can be rotated for ease of alignment.

5a. When the tool is positioned properly, press the trigger and hold it in until the pressing cycle is complete. The pressing cycle is complete when the standard Vic-Press jaw closes completely and the drive rollers return to the fully retracted position.

5b. Remove finger from trigger to prevent accidental startup of the tool.

5c. After the pressing operation is complete, release the standard Vic-Press jaw by squeezing the levers. Remove the tool from the fitting/pipe.

WARNING

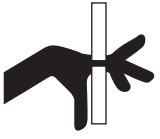

- **Keep fingers and hands away from the standard Vic-Press jaw and other pinch points during the pressing operation.**

Failure to follow this instruction could result in serious personal injury.

PRESSING OPERATION FOR 1 ½-INCH/48.3-MM AND 2-INCH/60.3-MM SIZES

WARNING

- Before operating the PFT510 Vic-Press Schedule 10S Tool, read the I-P500 Field Installation Handbook, and follow all instructions in the previous sections of this manual.
- Wear hardhat, safety glasses, foot protection, and hearing protection.
- The PFT510 Vic-Press Schedule 10S Tool is designed for use **ONLY** with Vic-Press Schedule 10S System Products. Refer to the “Introduction” section. **DO NOT** attempt to install Schedule 5 Pressfit Products with this tool.
- The proper size Vic-Press adapter jaw and Vic-Press ring must be used for the fitting and pipe size being installed.
- Inspect the tool, Vic-Press adapter jaw, and Vic-Press ring for loose, broken, or damaged parts before attempting to perform the pressing operation.
- **DO NOT ALTER THE PFT510 VIC-PRESS SCHEDULE 10S TOOL OR JAWS IN ANY WAY. ALTERATIONS TO ANY TOOL COMPONENTS MAY RESULT IN IMPROPER PRODUCT INSTALLATION AND WILL VOID THE VICTAULIC WARRANTY.**
- Keep fingers and hands away from all pinch points during the pressing operation.

Failure to follow these instructions could result in serious personal injury, property damage, and joint failure.

1. Check the Vic-Press adapter jaw and Vic-Press ring for damage or wear before attempting to perform the pressing operation. Damaged or worn components should be returned to a Victaulic-authorized service facility.

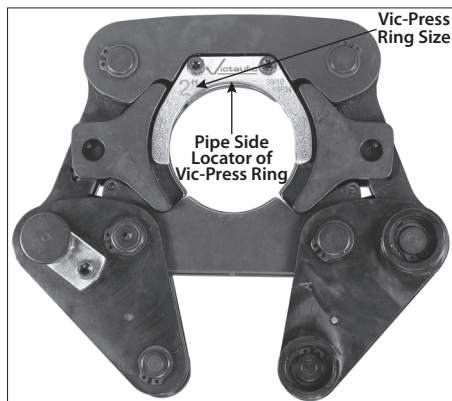

2. Select the proper size Vic-Press ring for the fitting and pipe size being installed. **NOTE:** The Vic-Press ring size is stamped on the “pipe side” locator of the Vic-Press ring.



3. Pull the latching pin of the Vic-Press ring out until it disengages the Vic-Press ring arm. Allow the Vic-Press ring to open completely, as shown above.

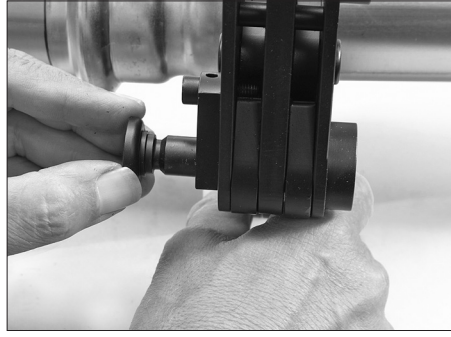
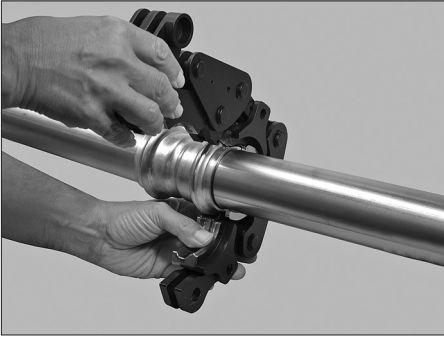

4. Wrap the Vic-Press ring around the fitting so that the Vic-Press ring cavity aligns/engages with the seal pocket bead of the fitting. **NOTE:** The Vic-Press ring can be installed only one way, with the “pipe side” locator over the pipe. If the “pipe side” locator is positioned toward the middle of the fitting, the Vic-Press ring will not close. **DO NOT ATTEMPT TO REMOVE THE “PIPE SIDE” LOCATOR FROM THE VIC-PRESS RING. ALTERATIONS TO ANY TOOL COMPONENTS MAY RESULT IN IMPROPER PRODUCT INSTALLATION AND WILL VOID THE VICTAULIC WARRANTY.**

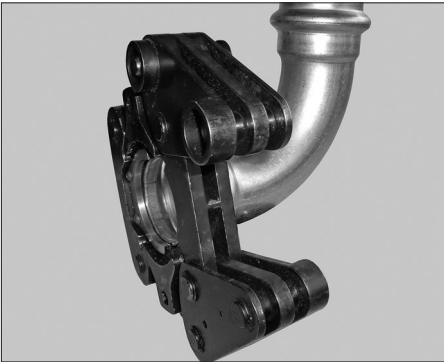
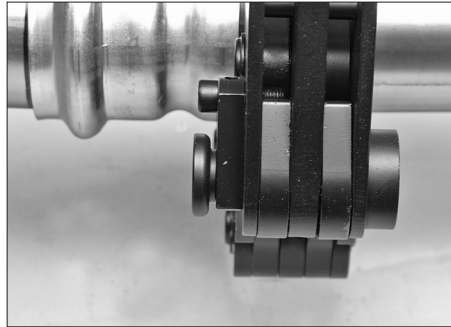

5. Close the Vic-Press ring by aligning the holes of the two ends. Push the latching pin through the Vic-Press ring arm completely, as shown above. **NOTE:** The Vic-Press ring can be rotated around the fitting for ease of tool positioning.

To ease handling, the Vic-Press ring can be installed onto the fitting prior to inserting the pipe ends into the fitting, as shown above.

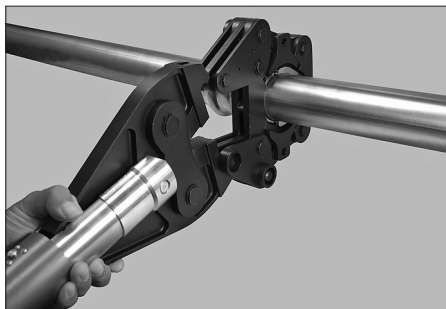

6. Install the Vic-Press adapter jaw into the tool by following the “Tool Setup” section.

6a. Open the Vic-Press adapter jaw by squeezing the levers. Align the hooks of the Vic-Press adapter jaw with the Vic-Press ring, as shown above.

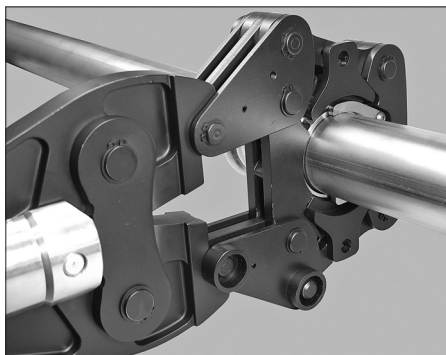

7. Engage the Vic-Press adapter jaw hooks into the Vic-Press ring, and release the levers. Make sure all four hooks of the Vic-Press adapter jaw engage completely with the Vic-Press ring.

7a. While positioning the standard Vic-Press adapter jaw and Vic-Press ring, make sure the pipe remains inserted fully in the fitting. The end of the fitting must be flush with the pipe mark. Always refer to the I-P500 Field Installation Handbook for pipe preparation and marking requirements.

CAUTION

- Make sure the seal pocket bead of the fitting is seated fully in the Vic-Press ring cavity before performing the pressing operation.

Failure to follow this instruction will cause an improper press, resulting in property damage.

WARNING

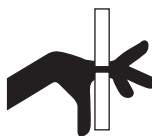

- Keep fingers and hands away from the Vic-Press adapter jaw and other pinch points during the pressing operation.

Failure to follow this instruction could result in serious personal injury.

8. Keep hands away from the Vic-Press adapter jaw and other pinch points at all times during the pressing operation.

8a. When the tool is positioned properly, press the trigger and hold it in until the pressing cycle is complete. The pressing cycle is complete when the Vic-Press adapter jaw closes completely on the Vic-Press ring and the drive rollers return to the fully retracted position.

8b. Remove finger from trigger to prevent accidental startup of the tool.

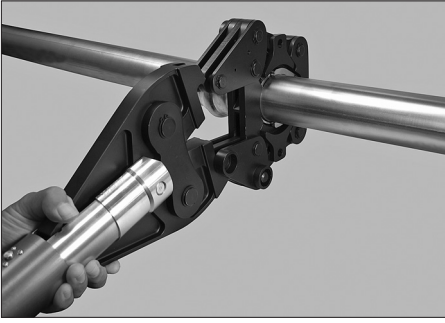

8c. After the pressing operation is complete, release the Vic-Press adapter jaw from the Vic-Press ring by squeezing the levers. Remove the tool from the Vic-Press ring.

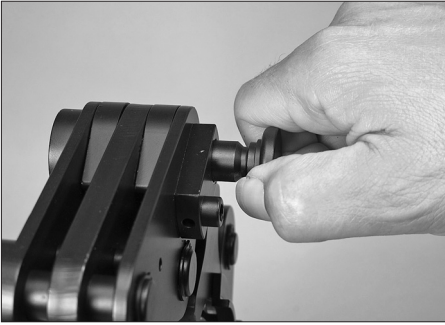

8d. Remove the Vic-Press ring from the fitting by pulling the latching pin out until it disengages the Vic-Press ring arm, as shown in Step 3 of this section.

STANDARD VIC-PRESS JAW OR VIC-PRESS ADAPTER JAW REMOVAL

WARNING

- Use caution when releasing the locking pin. The locking pin is under spring-loaded pressure.
- To prevent damage, do not drop the standard Vic-Press jaw/Vic-Press adapter jaw.

Failure to follow these instructions could result in serious personal injury.



1. Release the locking pin by pushing in and turning counterclockwise. Use caution when releasing the locking pin. The locking pin is under spring-loaded pressure. Remove the standard Vic-Press jaw or Vic-Press adapter jaw from the tool.

MAINTENANCE

WARNING

- Remove the battery from the tool before lubricating any tool components.
- **DO NOT ALTER THE PFT510 VIC-PRESS SCHEDULE 10S TOOL OR JAWS IN ANY WAY. ALTERATIONS TO ANY TOOL COMPONENTS MAY RESULT IN IMPROPER PRODUCT INSTALLATION AND WILL VOID THE VICTAULIC WARRANTY.**

Failure to follow these instructions could result in serious personal injury and improper product assembly.

After approximately 10,000 presses, or at least once per year, the tool, standard Vic-Press jaws, Vic-Press adapter jaw, and Vic-Press Rings should be returned to a Victaulic-authorized service facility for inspection. **NOTE:** The tool is equipped with a maintenance/fault indicator LED. Refer to the "Indicator Lights/Sounds" table on page 20 for additional information.

If pressing power is insufficient, or if the tool is losing oil, the tool must be returned to a Victaulic-authorized service facility for repair. Damaged or worn standard Vic-Press jaws, Vic-Press adapter jaws, and Vic-Press rings CANNOT be repaired and must be replaced with new, Victaulic-supplied components.



1. Remove the battery from the tool by depressing the button, as shown above.

WARNING

- Wear safety glasses when working with compressed air to prevent debris from entering eyes.

Failure to follow this instruction could result in serious personal injury.

DO NOT use cleaning solvents, turpentine, paint thinners, etc. to clean plastic parts. DO NOT immerse the tool in liquid.



2. Clean the drive rollers and the locking pin with a brush or compressed air.

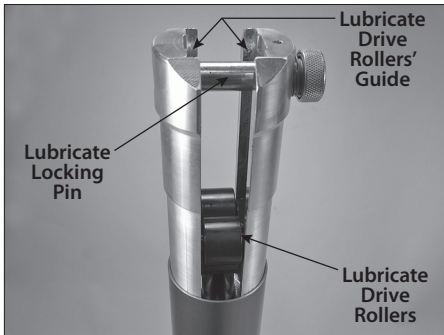

3. Lubricate the drive rollers' guide with a light grease.

3a. Lubricate the drive rollers with a light machine oil.

3b. Lubricate the locking pin with a light machine oil.

4. Clean plastic components (i.e. batteries, tool housing, etc) with a mild soap and damp cloth.



5. Remove deposits from the pressing cavities of the standard Vic-Press jaws with a wire brush.



6. Remove deposits from the pressing cavities of the Vic-Press rings with a wire brush.



Battery and Battery Charger Maintenance

NOTICE

- Damaged batteries and/or battery chargers should be replaced immediately.
- Do not dispose of batteries with normal domestic waste. Batteries must be disposed of properly, in accordance with local environmental requirements.

1. Remove the battery from the battery charger and disconnect the battery charger from the AC power source before attempting to perform any maintenance.
2. Clean the battery and battery contacts with a damp cloth. DO NOT submerge parts. Ensure the contacts and vent areas of the battery charger are free from debris.

7. Use compressed air to remove any loose debris from the pressing cavities of the standard Vic-Press jaws and Vic-Press rings.

8. Lubricate any pivot points on the standard Vic-Press jaws, Vic-Press adapter jaws, and Vic-Press rings with a light machine oil.















9. Coat the entire standard Vic-Press jaw, Vic-Press adapter jaw, and Vic-Press rings with an industrial grade lubricant/anti-corrosion spray.

10. Charge the batteries by following the “Battery and Battery Charger Information” section.

TROUBLESHOOTING

PROBLEM	POSSIBLE CAUSE	SOLUTION
Tool does not operate.	The rechargeable battery is faulty or has completely lost its charge.	Replace the battery with a new, fully-charged battery of the same voltage (supplied by Victaulic).
	The tool is faulty or has been damaged.	Contact Victaulic.
Tool does not finish the pressing operation. Vic-Press jaw does not close completely.	The tool is overloaded or has been used for pressing non-permitted pipe materials.	Use the tool only with pipe materials listed in this manual.
	Dirt or deposits are between the Vic-Press jaw levers or in the pressing contour of the Vic-Press jaw.	Clean the Vic-Press jaw by following the "Maintenance" section.
	The tool is faulty or has been damaged.	Contact Victaulic.
	The rechargeable battery has run low during the pressing operation.	Replace the battery with a fully-charged battery of the same voltage (supplied by Victaulic).
	The press jaw being used is not compatible with the tool.	Use only PFT510 Vic-Press jaws for Vic-Press Schedule 10S System Products (supplied by Victaulic).
	The locking pin is not inserted correctly.	Push the locking pin completely through the Vic-Press jaw and into the tool until it clicks.
During the pressing operation, a ridge is created on the fitting.	Damaged or worn Vic-Press jaw/Vic-Press jaw contour.	Replace the Vic-Press jaw with a new, Victaulic-supplied Vic-Press jaw for Vic-Press Schedule 10S System Products (supplied by Victaulic).
	The Vic-Press jaw being used is not the correct size.	Replace the Vic-Press jaw with the correct size for the pipe/fitting being installed.
	The press jaw is not intended for use with Victaulic Vic-Press Schedule 10S System Products.	Use only PFT510 Vic-Press jaws for Vic-Press Schedule 10S System Products (labeled with the Victaulic logo).
	Fitting and pipe sizes are not matched up correctly.	Use corresponding fitting/pipe sizes with the proper size Vic-Press jaw for Vic-Press Schedule 10S System Products (supplied by Victaulic).

INDICATOR LIGHTS/SOUNDS

			OCCURS	CAUSE OR RESULT
 20 Seconds			After working cycle	Low battery
 2 Times			After inserting the battery	Self check
 20 Sec/2 Hz			After working cycle	Return tool to Victaulic for servicing
 20 Sec/5 Hz			During working cycle	Temperature limit has been exceeded
 20 Seconds  20 Sec/2 Hz			After working cycle	Return tool to Victaulic for servicing
 1 Time			After working cycle	The required pressure has not been reached due to the operator interrupting the pressing cycle while the motor was running
 3 Times	 3 Times		After working cycle	The required pressure has not been reached due to mechanical error while the motor was running/ Return tool to Victaulic for servicing





EC DECLARATION OF CONFORMITY

Issued In Accordance with the
MACHINERY DIRECTIVE 2006/42/EC

Victaulic Company, headquartered at 4901 Kesslersville Road, Easton, PA 18040, USA, as the commercial representative of Gustav Klauke GmbH, (Auf dem Knapp 46, D-42855, Remscheid, Germany) hereby declares that the product listed below complies with Annex I - Essential Health and Safety Requirements Relating to the Design and Construction of Machinery, in accordance with the Machinery Directive, 2006/42/EC.

<u>Product Model Designation :</u>	PFT510 Vic-Press™ Tool	
<u>Product Description:</u>	18V DC Hand Held Pressing Tool for assembly of Victaulic Vic-Press Schedule 10S System Products.	
<u>Conformity Assessment:</u>	Conformity assessed by Gustav Klauke GmbH in accordance with Annex I.	
<u>Note Regarding Applications:</u>	Vic-Press products are not intended for use with toxic, flammable, explosive, oxidizing or other hazardous substances.	
<u>Other Reference Standards:</u>	IEC 60745-1 1/2010	EN-61000-6-2
	EN-349	EN-61000-6-3
	EN-982	EN-5349 T1
	EN-1037	EN-5349 T2

i.v.

Signed:		
Name:	<u>Mr. Joh.-Christoph Schütz</u>	<u>Mr. Len R. Swantek</u>
Title:	<u>Dipl.-Ing CE Beauftrager</u>	<u>Director - Global Regulatory Compliance</u>
Date:	<u>October 5, 2012 Gustav Klauke GmbH, Manufacturer</u>	<u>October 5, 2012 Victaulic Company, Commercial Representative</u>

MD DOC PFT510
Rev B
Page 1 of 1

PFT510

BATTERY-POWERED VIC-PRESS™ TOOL FOR VIC-PRESS SCHEDULE 10S SYSTEM PRODUCTS

For complete contact information, visit www.victaulic.com

TM-PFT510 6230 REV D UPDATED 10/2012 RM00PFT510

VICTAULIC IS A REGISTERED TRADEMARK OF VICTAULIC COMPANY. © 2012 VICTAULIC COMPANY.
ALL RIGHTS RESERVED. PRINTED IN THE USA.

